



INSTALLATION, OPERATION AND MAINTENANCE MANUAL



Air Curtains L, XL three phases

Please, read these instructions carefully before attempting installation

SECURITY ADVISE SIMBOLS



Attention, Danger, Safety Advice!



Danger from electric current of high voltage!



Injuries risk!



Danger! Do not step underneath: Heavy load.



Important Information!

INDEX

CONNECTION DIAGRAM UNHEATED OR WATER HEATED.....	3
CONNECTION DIAGRAM. ELECTRICAL HEATING	5
INSTALLATION	7
Power Supply	8
PCBoard and control	8
Fixing.....	8
Water coils	8
Electrical elements	8
STORAGE AND TRANSPORT.....	9
WORKING INSTRUCTIONS	9
Control PCBoard characteristics	9
Controller's common characteristics.....	9
Common characteristics to all controllers for water heated air curtains	10
Special controllers	11
Remote control characteristics	11
DATASHEET	12
WIRING DIAGRAMS	14
MAINTENANCE INSTRUCTIONS.....	27
REPAIRS AND REPLACEMENTS	28
Fan replacement	29
Fuse and PCB replacement	29
Heat exchanger or coil replacement.....	30
Fixation points of coils and heaters	30
FAILURES AND SOLUTIONS	31
ACCESSORIES.....	33
DECLARATION OF CONFORMITY	34
WARRANTY	35

CONNECTION DIAGRAM UNHEATED OR WATER HEATED

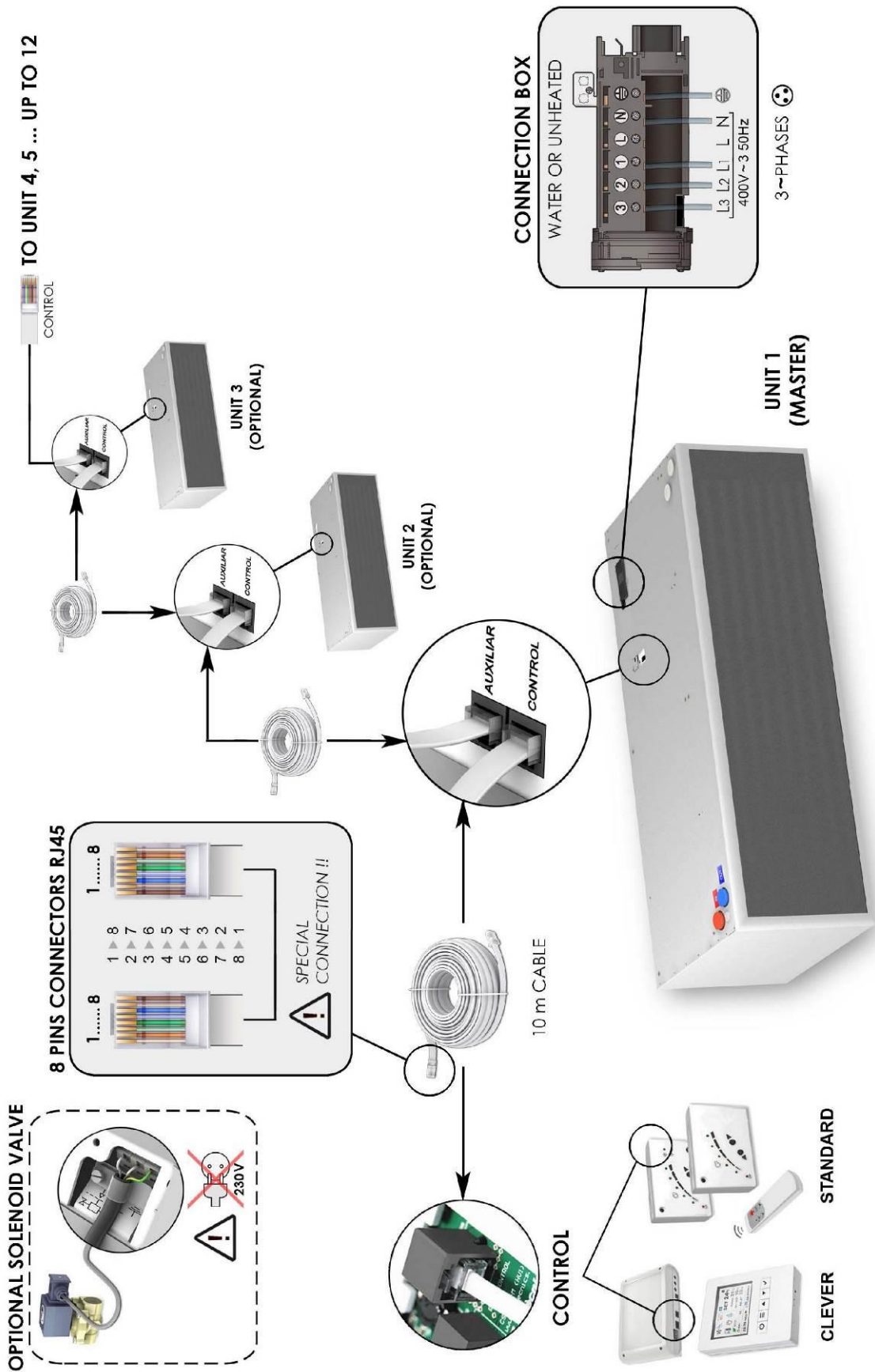

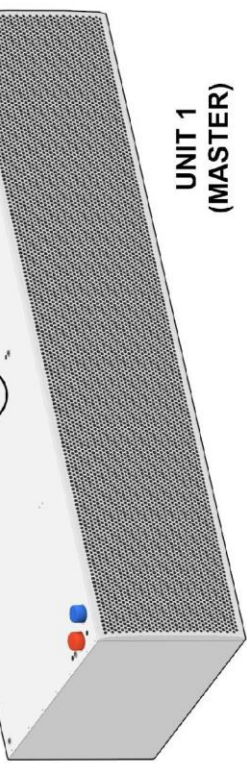
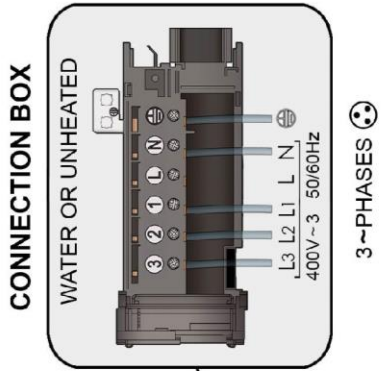
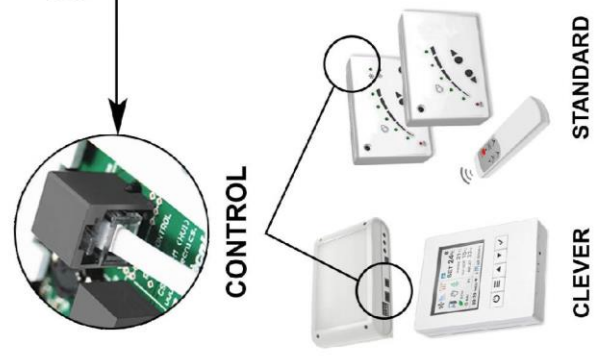
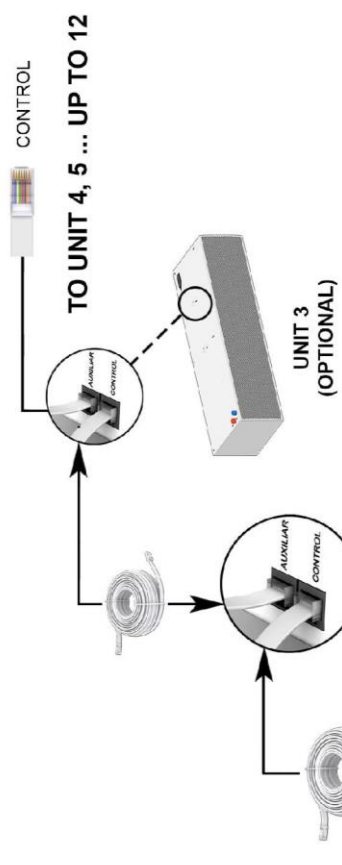
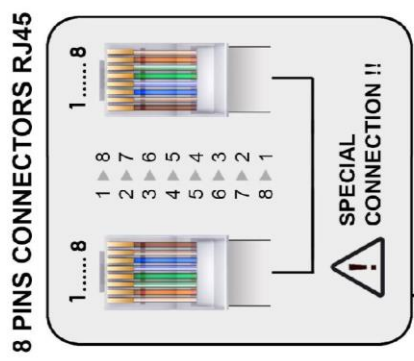
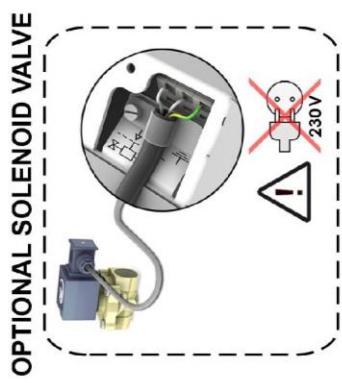

Windbox L, XL models with 2 PCB

50 Hz	L	-	2500	3000
	XL	-	2500	3000
60 Hz	L	-	2500	3000
	XL	2000	2500	3000

CONNECTION DIAGRAM. ELECTRICAL HEATING

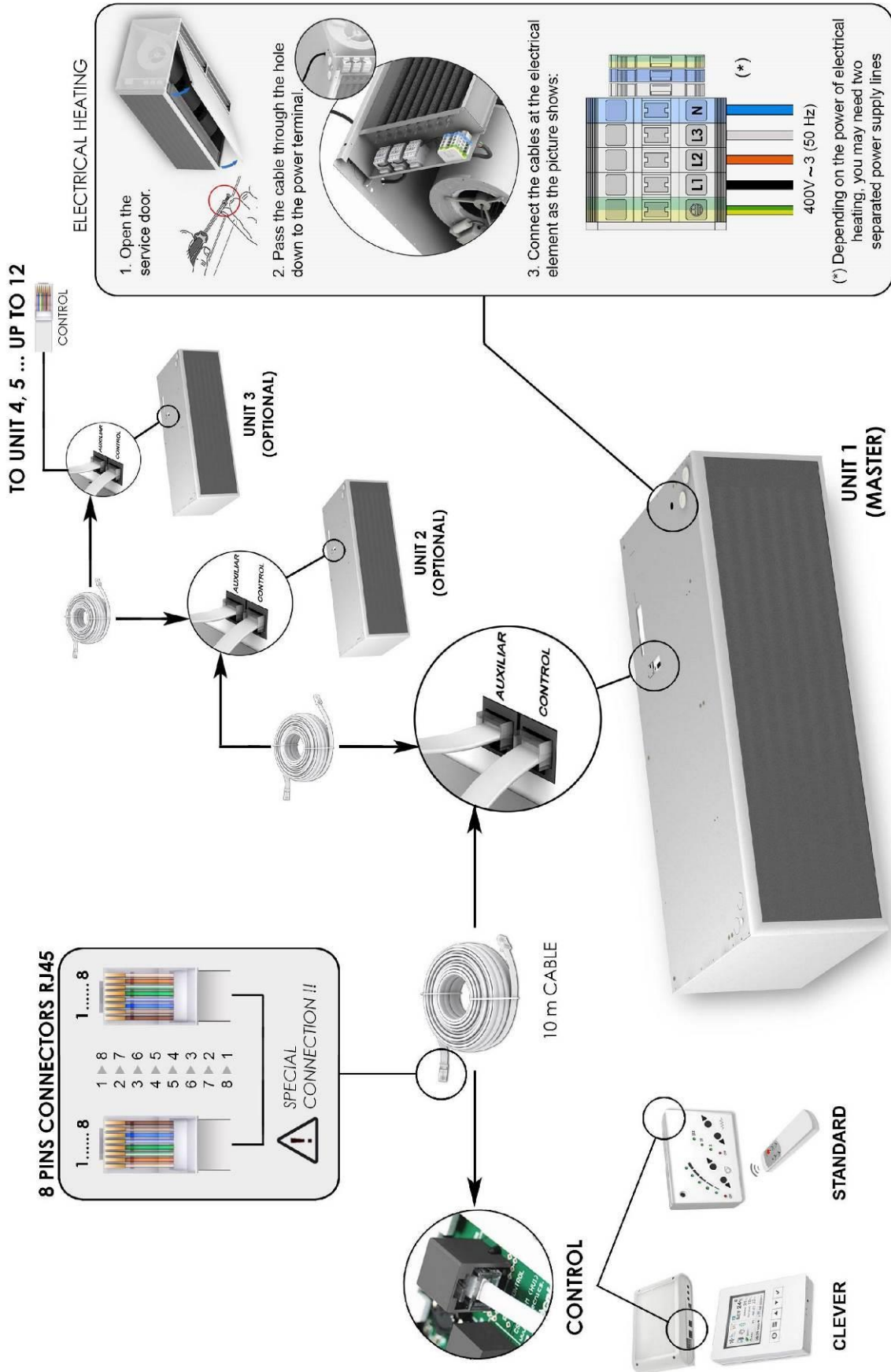

Windbox L, XL models with 2 PCB

50 Hz	L	-	2500	3000
50 Hz	XL	-	2500	3000
60 Hz	L	-	2500	3000
60 Hz	XL	2000	2500	3000

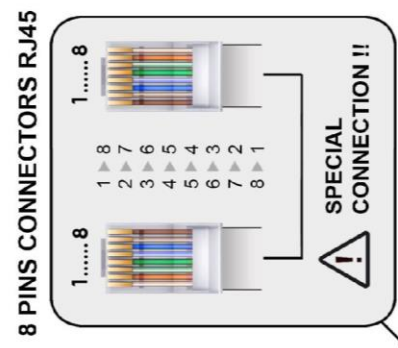

TO UNIT 4, 5 ... UP TO 12 CONTROL

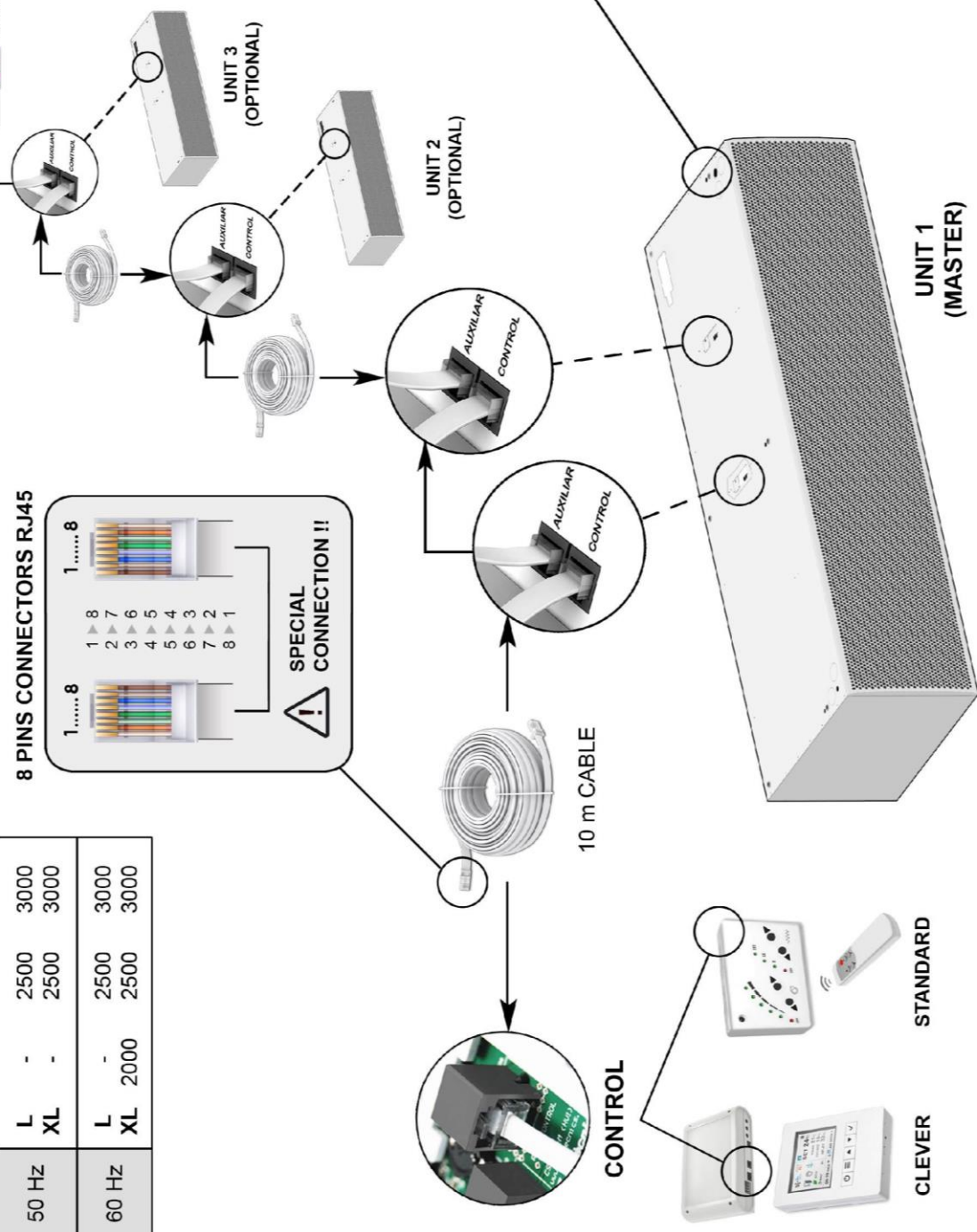

ELECTRICAL HEATING

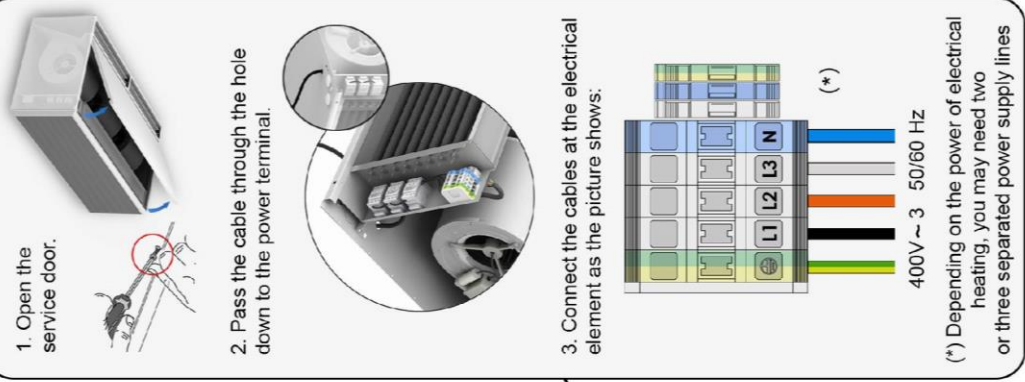

INSTALLATION

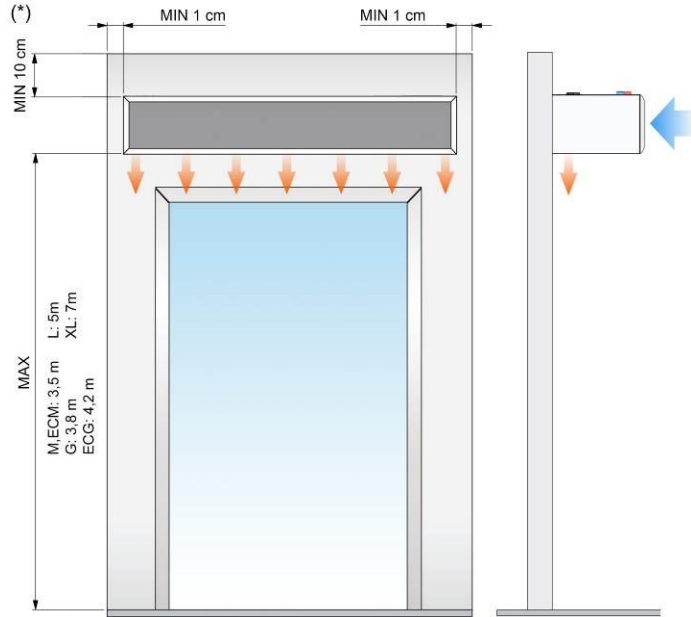

MAX. Maximum recommended height, MIN Minimum recommended distance.

(*) Standard units. Under request this distance can be reduced to 1cm when connections are placed inside and water pipes lateral.

Minimum recommended distance between the inlet grille and any obstacle is of 100mm

	<p>Installation work, connection, disconnection, electrical wiring, mechanical maintenance and service must be done by qualified persons observing these instructions and in accordance with all applicable norms and standards.</p> <p>If the unit is operated with additional controller, please consider its specific instructions.</p>
	<p>There is no need to open the service door to connect the air curtain. All connections (power supply, control, water pipes when existing) and fixations are external. They are placed on top or lateral of the units. See how to open service door at repairs section.</p>
	<p>For safety, the air curtains never have to be stopped by disconnecting from the main supply, always through the controller and wait for 10 minutes at least to disconnect the main supply. In case we do not follow these instructions, the internal parts of the air curtain can be damaged.</p>
	<p>When the installation of the regulator is finished, it is compulsory to check the correct direction of rotation fan, likewise check that there is no error message in the regulator.</p>
	<p>Each machine need to have an electrical protection system according the regulations of the country, circuit breakers, Interrupters Differentials, earths points, etc.</p>
	<p>The wiring used by the installer should comply with regulations of the country, and the section of the wire must bear the working of the equipment at its maximum power.</p>
	<p>Do not expose the electrical parts to water, humidity, corrosive ambient (even chlorine)</p>
	<p>Maintenance or installing works always must be done without tension by disconnecting the main supply.</p>
	<p>If the regulation does not work because external error has shown up, check the input (there is current in the three phases) and if this is correct change two out of three input wires. For instance L1 with L2 or L2 with L3 or L1 with L3.</p>

Power Supply

To connect the power supply there is a black connection box outside the air curtain (on top or lateral)

Air curtain just connect the three phase 400Vx3 with neutral.

In case of an air curtain with electrical heating we will also connect the three phase 400Vx3 of the electrical element and the power supply on the electrical element.

The input of the PCBoard is 400V with neutral and earth point. The order of the phases is very important, if it is incorrect, the control will show all its intermittent LED, to solve this change two out of three phases. Connect L1, L2, L3, N, PE.

PCBoard and control

To connect the controller there is a PCBoard (printed circuit) located: outside the air curtain (on top or lateral). There is no need to open the unit to connect it.

Use the telephone cable of 10 meters (RJ45 connectors) supplied with the equipment. The communication between the connector plate and the controller is digital through low-voltage.

Optionally, there are available different accessories and controllers, to meet every customer's needs (week timer, thermostats, door contacts, anti-freezing sensor, supports, valves, etc...).

Fixing

Units are provided with several external suspension points, depending on the weight and length (see exact situation of the points at the air curtains characteristics page). Generally air curtains work horizontally but also can be installed vertically using feet (accessories section).

The anchor should be managed according to the weights of each unit shown on the technical data page. The installation can be made through threaded rods, tensors or other supports. See available supports in the accessories section.

Water coils

Water heated air curtains have a PCBoard with an output of 230Vx1 to install an electro valve (open/close water entrance) or any other device.

It is recommended:

- Close the warm water circulation (by closing the electro valve) to avoid motor overheating while the unit is OFF. The electro valve is optional.
- Install 2 shut-off water valves (supply and return) in order to dismantle the equipment easily.
- Install a bleeding point at the highest part of the heating water circuit.

The ambient temperature should be always over +4°C, otherwise it will be necessary to provide an anti-frost protection device.

Water coils have a draining point placed at the end part of the intake manifold. Some special units with condensation tray prepared to work with cold water can't work at high ventilation speed (depending on model and length). Suction air with higher speed of 3m/s should be avoided because water drops can appear on the outlet.

Electrical elements

The heat exchanger has different resistances in bar form that combined among them give us 3 stages of heating. The control is made through some contactors.

All electrical elements are protected electrically and electronically against overheating (see “operating instructions” section).

The electric controllers have the option to install an external thermostat that turns on/off the heating in order to control the temperature

During the first uses scent can be emitted but it disappears in a few days

STORAGE AND TRANSPORT



Attention! Heavy load.

Do not step under hanging load during the transport or assembly

Store in a dry place and weather protected in its original packaging. In case the packing is open, cover the air curtain to protect it from dust. Do not step or put heavy load over the package to avoid damages to the material. Store temperatures are between -20°C and +40°C.

When carrying material, make sure it is not damaged by the forklift (fork penetration in the packaging). Please see the packaging indications.

WORKING INSTRUCTIONS



For safety, the air curtains never have to be stopped by disconnecting from the main supply, always through the controller and wait for 10 minutes at least to disconnect the main supply. In case we do not follow these instructions, the internal parts of the air curtain can be damaged

Control PCBoard characteristics

It adjusts the fan speed through the input voltage variation of the set of fans. The transformer has 5 output voltages: 120, 140, 170, 200 and 230 Volts.

Controller's common characteristics

- **Controllers:** There are several models depending on the customer's needs (timers, anti-freezing detectors, thermostats, etc...).
- **5 ventilation speeds**
- **Memory:** It guarantees that in the event of a power shortage, the selected speed will be maintained when the service is re-established. This function can be connected-disconnected through the switch ON/OFF placed inside the controller.
- **Telephone cable and digital communication:** “Plug and Play” easy and fast connection through telephone cable and digital communication between the controller and the air curtain. This kind of communication is more reliable even at long distances.
- **External ON/OFF:** Inside the controller we can connect a normally open contact (1, 2) that controls the ON/OFF of the equipment through any external device, the contact is potential-free. When the contact is Open, the air curtain is ON. When closed contact, air curtain is OFF. It has a 30 seconds delay. It can be used with programmable timer, temperature sensors, fire alarms, PLC, door contact, etc...
- **Remote control:** All the standard controllers have an IR receiver that works by infrared.

Common characteristics to all controllers for water heated air curtains



Unheated air curtain controller

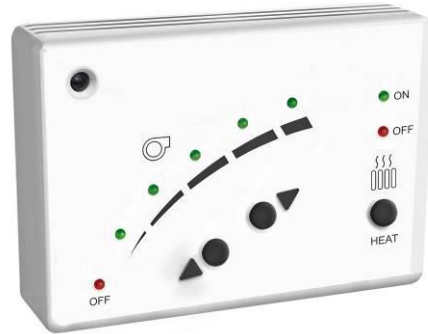

Warm water heated air curtain controller

- **Heating ON/OFF:** It is possible to activate/deactivate the current of 230Vx1 to the electrovalve to open/close the water entrance to the coil. This 230Vx1 output connector is placed on top of the equipment, besides the telephone cable connection of the controller.
- **How to control an electro-valve with an external thermostat:** To control the inlet water to the battery through a thermostat, we must install it in series with the electro-valve. Thus, when it reaches the selected temperature, the electro-valve will close.
- **Safety thermostat:** If the internal temperature increases to 60°C and the first speed being selected, it automatically turns to the second ventilation speed. It will continue to the maximum speed till the internal temperature is lower than 50°C. The emergency operating is indicated by a flashing LED. If the safety activates too often the cause must be determined. The most probable is that we have to increase the cleaning of the inlet grill with more regular recurrence. For example, an obstruction in the inlet grill, the inactive motor or a too high ambient temperature in an installation with no ambient thermostat or a water temperature of the water coil over 80°C would increase automatically the speed fan. It also avoids that the expelled air by the air curtain is over 60°C (too high temperature sensation for people).

Common characteristics to all controllers for electrical heated air curtains

Equipment of five ventilation speed and three different heating powers (C1, C2, C3= [C1 + C2]).

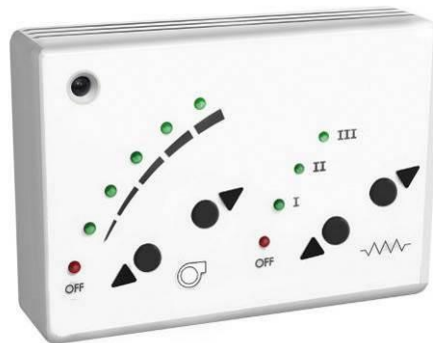

- **3 Heating powers:** C1=1/3 Total, C2=2/3 Total, C3=C1+C2=Total.
- **Limited heating powers:** For safety reasons of the equipment, the heating power is limited by the ventilation speed that we had selected, the following way:

Selected speed	Max. heating power that can be selected
V1	Stage 1 heating.
V2	Stage 2 heating.
V3	Stage 2 heating.
V4	Stage 3 heating (stage 1 + stage 2).
V5	Stage 3 heating (stage 1 + stage 2).
- **Thermostat of delay:** When the equipment is stopped, and the heating has been working, there is an increase in temperature (by inertia) inside the equipment that could damage it. In order to avoid internal damages by overheating, when we stop the curtain and the internal temperature is over 50°C, there is a delay thermostat having the function to turn on again the fans automatically with maximum speed till the temperature goes under 50°C. This safety operating is indicated with a flashing green LED.

- **Safety thermostat:** When the air curtain operates with heating and the internal temperature increases over 60°C, a safety function activates: The air curtain increases one speed every two minutes till it reaches the maximum speed. After, it will start decreasing 1 heating stage till it stops. In case that after 2 minutes the situation persists, the heating will block. To unblock it, we must manually reset by disconnecting from the main supply. If in any moment the temperature decreases (below the set temperature) this process is interrupted and everything goes back to the normal situation.

A delay in the cleaning of the inlet grille or a high ambient temperature could temporally activate this function.

The air speed and the heating stage are indicated by a continuous lighted LED, while the safety function is indicated by a flashing LED. The blockage of the heating is indicated with the LED OFF of the heating flashing at a higher speed.

Auxiliary functions of the controllers with electrical heating:

- **Ambient thermostat (digital o analogue):** with an ambient thermostat we can turn on and off the heating when reaching a programmed temperature. Its use is specially recommended in closed areas of little dimensions because otherwise the temperature would increase too much. In case on installing the ambient thermostat, remove the bridge of the controller between terminal 4 and 5.

Special controllers

If there is a will to control more parameters, there are two controllers that allow a lot more possibilities in comparison with the standard control, especially *Clever*. The following controllers have specific user manuals:

- Hand Auto
- Clever Control

Remote control characteristics

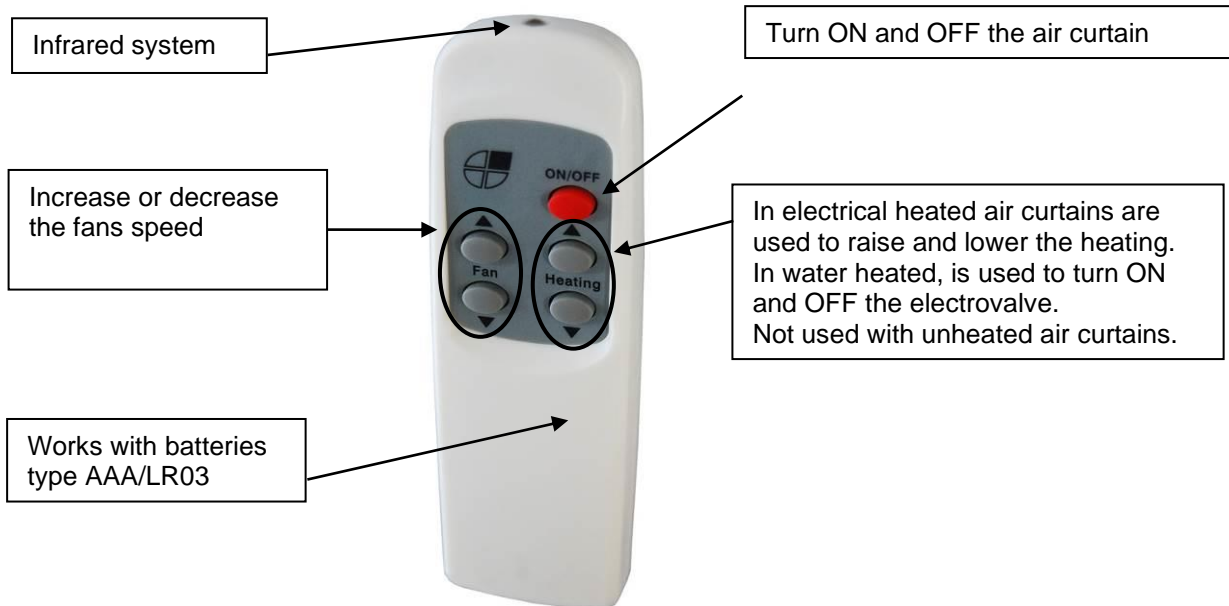

**WINDBOX XL 400Vx3 | High Pressure Air Curtains
For Commercial And Industrial Doors**



Characteristics



- Self-supporting casing construction made of galvanized steel plate, finished in structural epoxy-polyester painting white colour RAL9016 as standard. Other colours or stainless steel are available on request.
- Two frontal grille options. Industrial perforated by default.
- Anodized aluminium outlet vanes, airfoil shaped, adjustable from 0 to 15° each side.
- Double-inlet centrifugal fans driven by an external rotor motor and low noise level. 5-speed selector.
- “E” type with electrical shielded elements, three stages with integrated regulation. “A” type without heating, air only.
- Includes Plug&Play control with 10m RJ45 cable and infrared remote control. Optional: Clever control (programmable, automatic, intelligent, energy saving, Modbus RTU for BMS...).

Specifications

AIR ONLY

Model	Airflow m ³ /h	Fans Power 400Vx3-50Hz kW	Fans Current 400Vx3-50Hz A	Noise Level (5 m) dB(A)	Weight kg
XL 1000 A	5800	1,60	2,88	65	78
XL 1500 A	8700	2,40	4,32	66	117
XL 2000 A	11600	3,20	5,76	67	157
XL 2500 A	14500	4,00	7,20	68	192
XL 3000 A	17400	4,80	8,64	69	211

ELECTRICAL HEATED

Model	Airflow m ³ /h	Electrical Heating Capacity 400Vx3-50Hz kW	Fans Power 400Vx3-50Hz kW	Fans Current 400Vx3-50Hz A	Noise Level (5 m) dB(A)	Weight kg
XL 1000 E	5800	10/15/25	1,60	2,88	65	96
XL 1000 E-35	5800	10/25/35	1,60	2,88	65	96
XL 1500 E	8700	15/22,5/37,5	2,40	4,32	66	144
XL 1500 E-52	8700	15/37,5/62,5	2,40	4,32	66	150
XL 2000 E	11600	20/30/50	3,20	5,76	67	192
XL 2000 E-70	11600	20/50/70	3,20	5,76	67	200
XL 2500 E	14500	20/40/60	4,00	7,20	68	240
XL 2500 E-70	14500	20/50/70	4,00	7,20	68	250
XL 3000 E	17400	20/40/60	4,80	8,64	69	288
XL 3000 E-80	17400	30/50/80	4,80	8,64	69	300



Layouts and dimensions

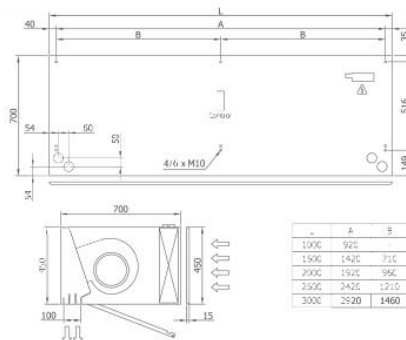

Free hanging mounting

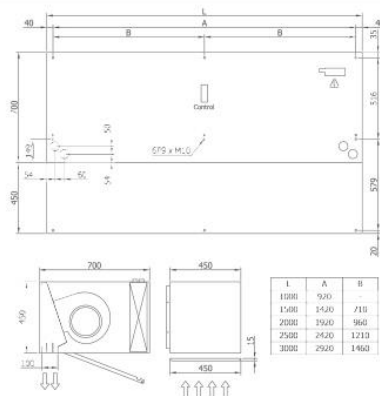

Inside ceiling surface mounting

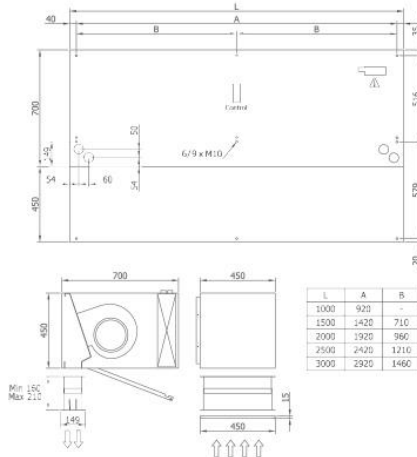

False ceiling invisible mounting

Grille Finishes

Industrial

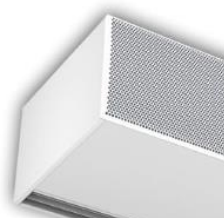

Decorative

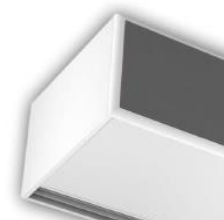

WIRING DIAGRAMS

Following connection diagrams are enclosed:

- Standard 5 speeds controller unheated and water heated, lengths 1000-1500-2000-2500.
Diagram: AIRDOE09950
- Standard 5 speeds controller unheated and water heated, lengths 3000. Diagram: AIRDOE09930
- Hand-Auto 5 speeds controller unheated and water heated, lengths 1000-1500-2000-2500.
Diagram: AIRDOE09952
- Hand-Auto 5 speeds controller unheated and water heated, lengths 3000. Diagram: AIRDOE09932
- Standard 5 speed controller electrical heated, length 1000. Diagram: AIRDOE09960
- Standard 5 speed controller electrical heated, length 1500-1000E35. Diagram: AIRDOE09962
- Standard 5 speed controller electrical heated, length 2000-2500. Diagram: AIRDOE09964
- Standard 5 speed controller electrical heated, length 1500E52-2000E70-2500E70.
Diagram: AIRDOE09968

For length 3000 and electrical heated consult.

In case you need to connect the equipment to a PLC, the corresponding connections diagrams will be supplied.

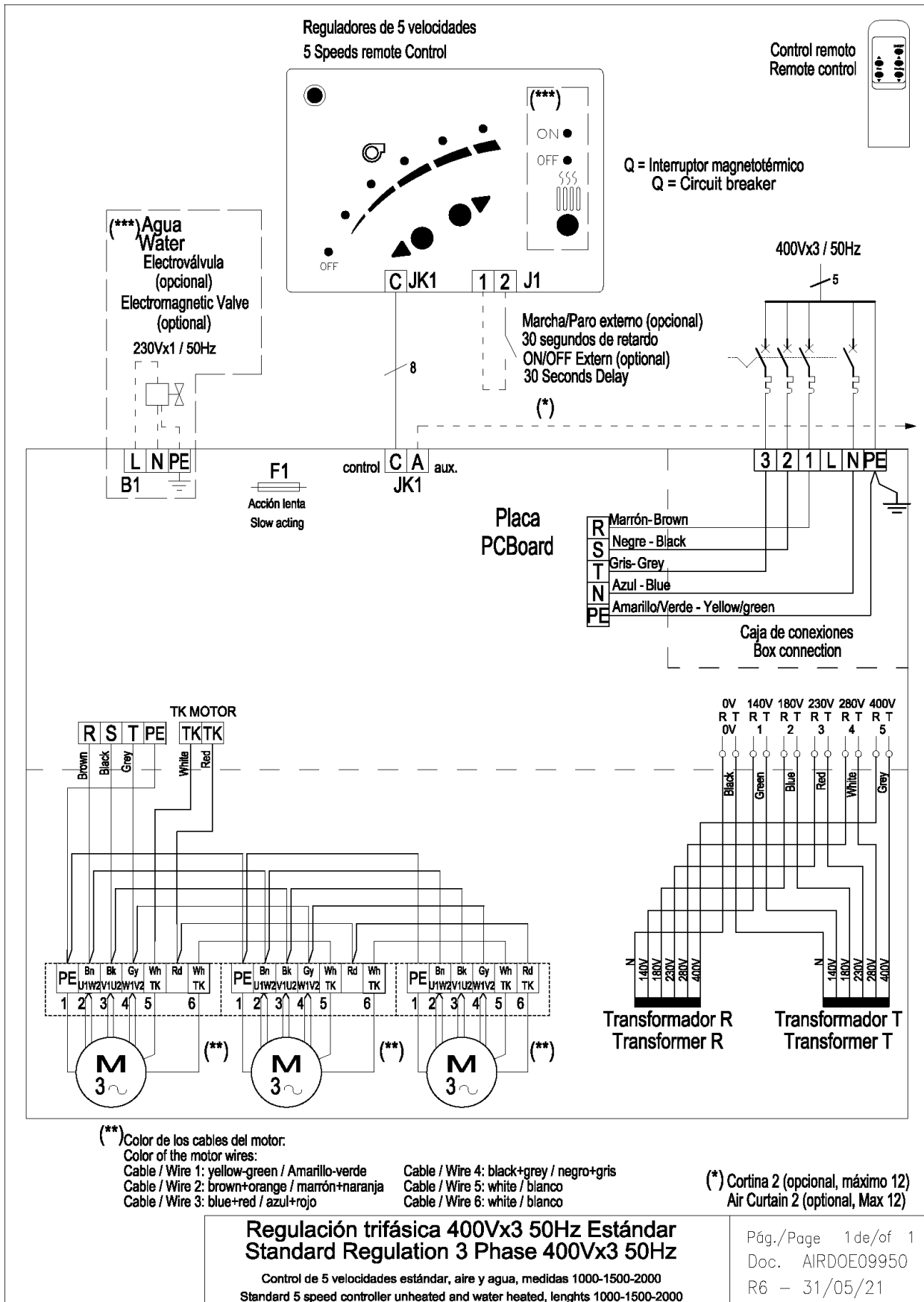

Reguladores de 5 velocidades
5 Speeds remote Control

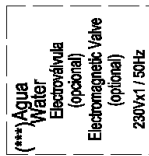
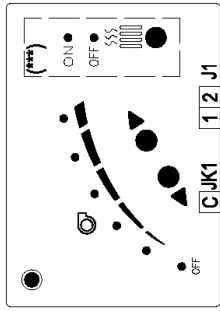

Control remoto
Remote control

Q = Interruptor magnetotérmico
Q = Circuit breaker

400Vx3 / 50Hz

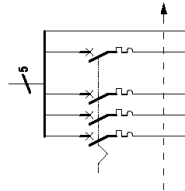

(*)

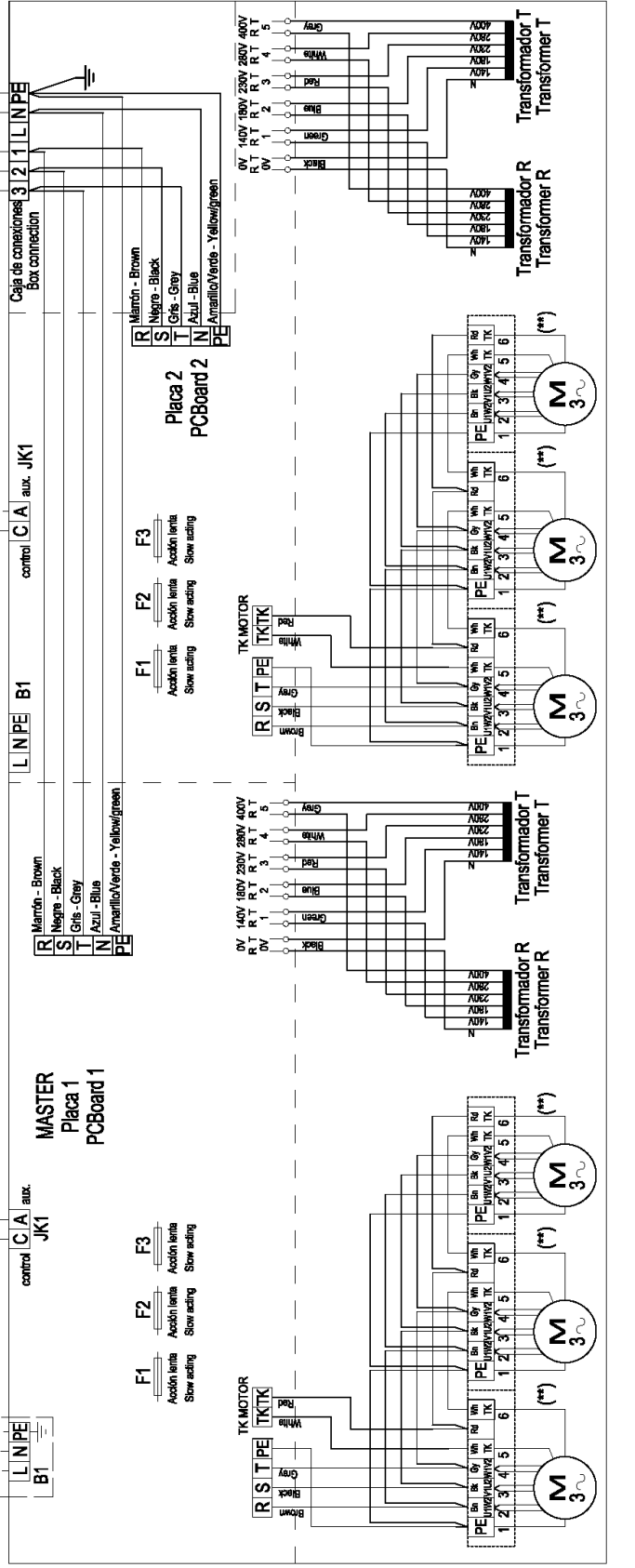

(*) Cortina 2 (opcional, máximo 12)
Air Curtain 2 (optional, Max 12)

Regulación trifásica 400Vx3 50Hz Estándar
Standard Regulation 3 Phase 400Vx3 50Hz
Control de 5 velocidades estándar, aire y agua, medidas 2500-3000
Standard 5 speed controller unheated and water heated, lengths 2500-3000

(**) Color de los cables del motor:
Color of the motor wires:

- Cable / Wire 1: yellow-green / amarillo-verde
- Cable / Wire 2: brown-orange / marrón-naranja
- Cable / Wire 3: white / blanco
- Cable / Wire 4: black-grey / negro-gris
- Cable / Wire 5: blue-red / azul-rojo
- Cable / Wire 6: white / blanco

Comprobar que el sentido de giro de los motores es el correcto, si no es correcto intercambiar dos fases de la alimentación.
 La protección térmica de los ventiladores es independiente de instalar o no un guardamotor, el contador no viene incluido pero es recomendable su montaje.

Check that the rotation direction of the motor is correct, if not you must change two phases of the power supply.
 Heat protection in the fans is independent of installing a motor-protection switch. The circuit breaker is not included but its installation is recommended.

Q = Interruptor magnetotérmico
 C = Circuit breaker

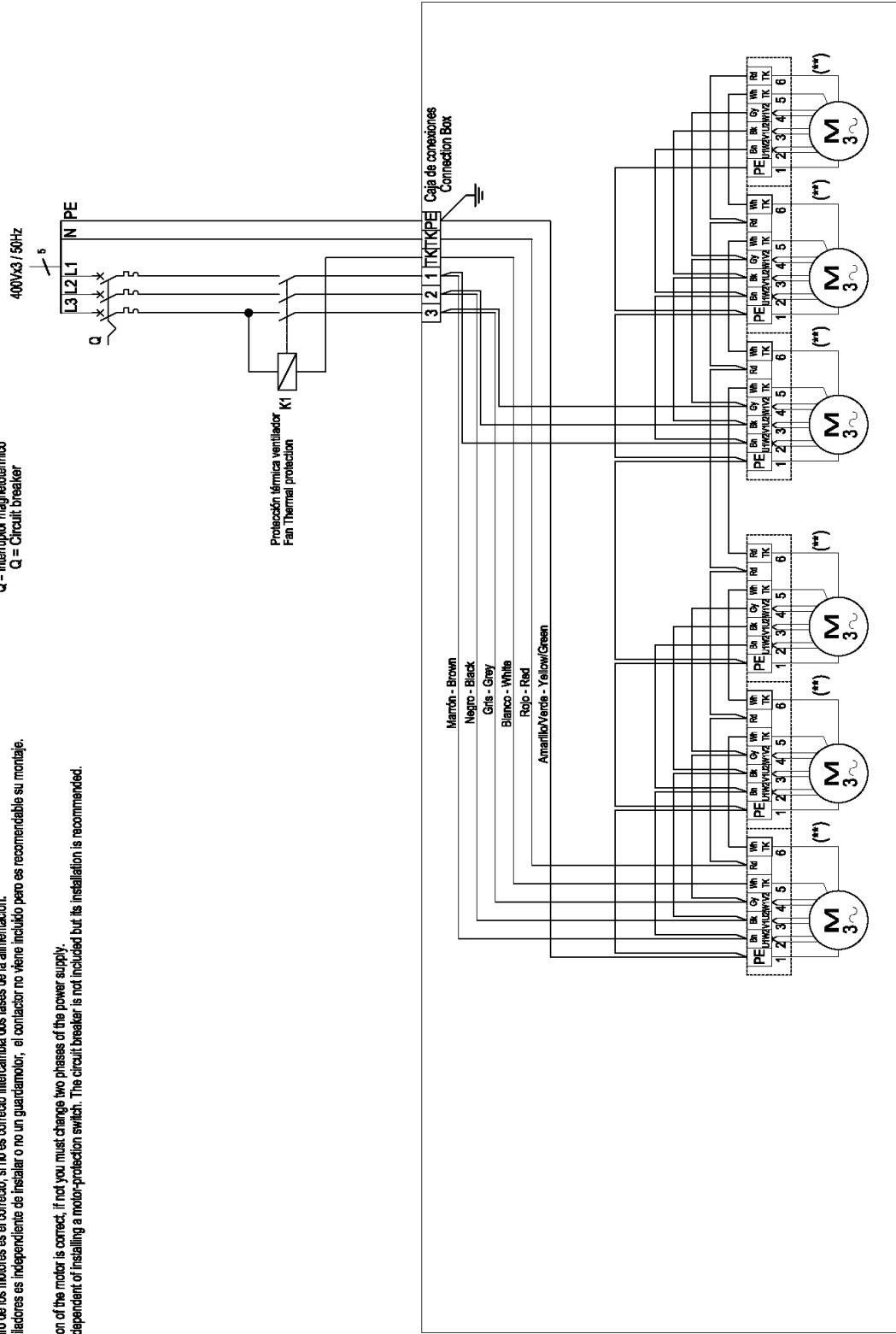

Cortina trifásica 400Vx3 50Hz Sin regulación
Air Curtain 3 Phase 400Vx3 50Hz Without regulation

Cortina XL, aire y agua, medidas 3000
 Air curtain unheated and water heated, lengths 3000

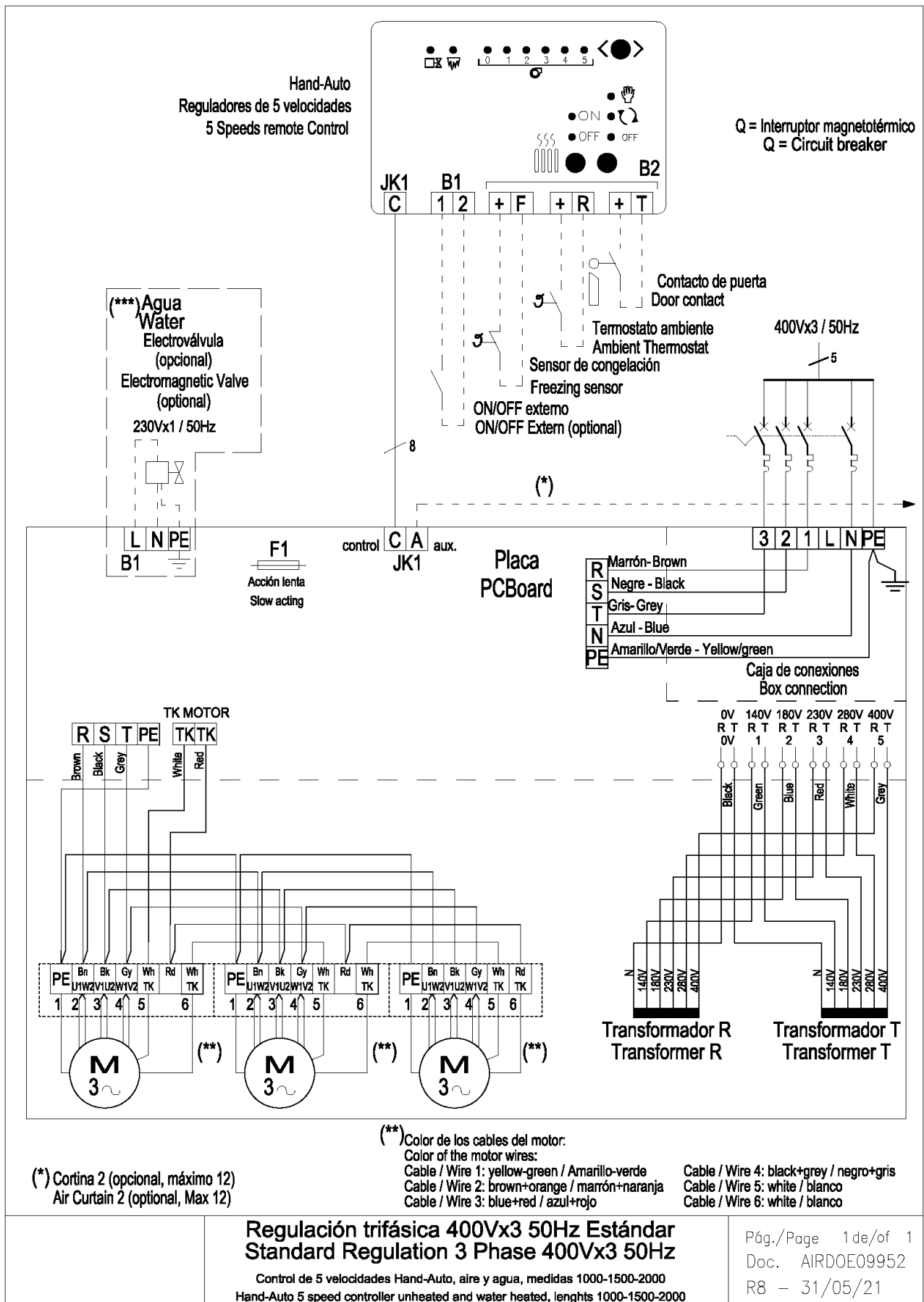

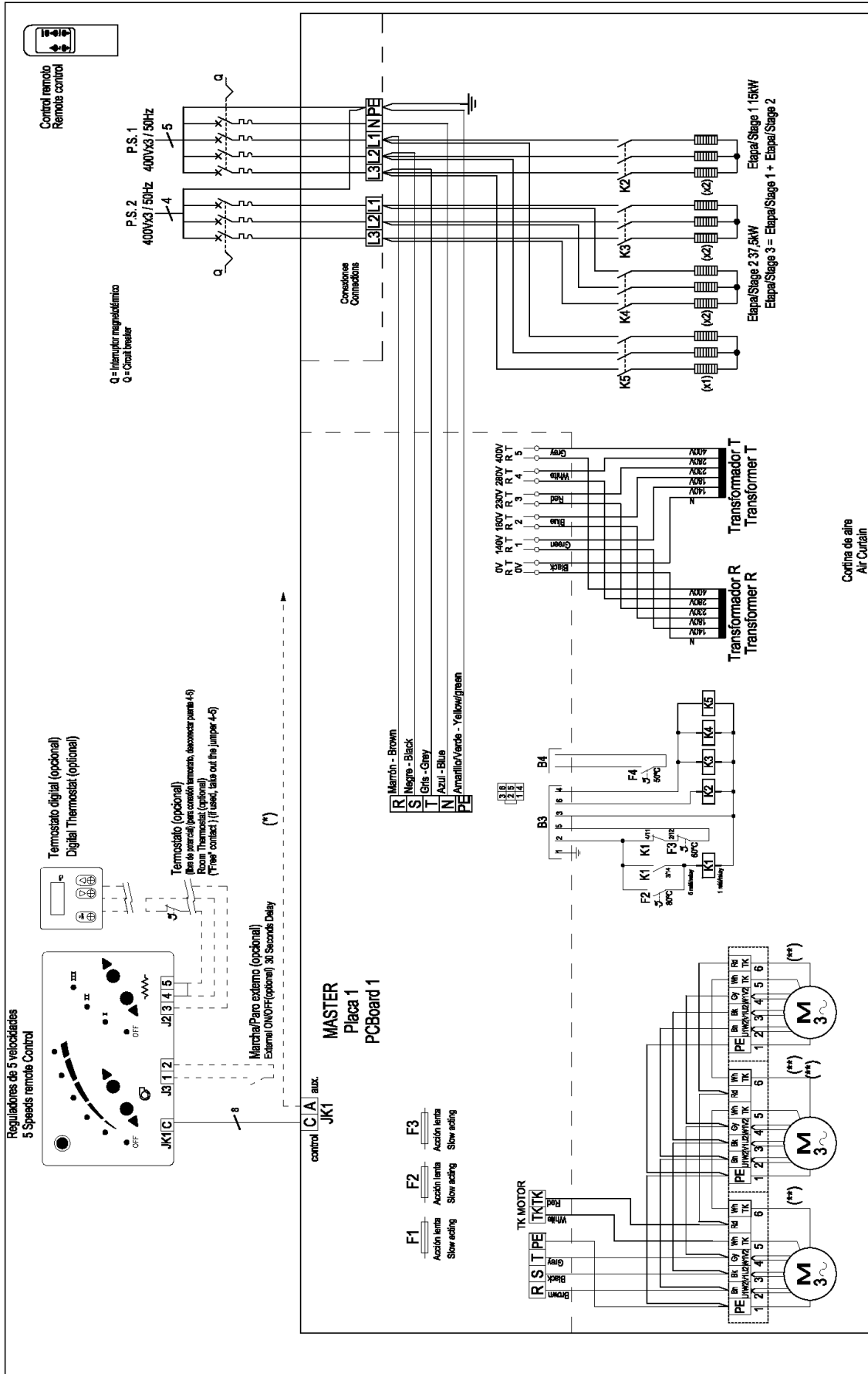

Regulación trifásica 400Vx3 50Hz Estándar
Standard Regulation 3 Phase 400Vx3 50Hz

Controlador 5 velocidades estándar, XL 1600 E52.5
ELECTRICAL CONTROLLER 5 SPEEDS, XL 1600 E52.5

(**) Color de los cables del motor.
Color of the motor wires:

Cable / Wire 1: yellow-green / amarillo-verde
Cable / Wire 2: brown-orange / marrón-naranja
Cable / Wire 3: blue-red / azul-rojo
Cable / Wire 4: black-grey / negro-gris
Cable / Wire 5: white / blanco
Cable / Wire 6: white / blanco

(*) Cortina 2 (opcional, máximo 12)
Air Curtain 2 (optional, Max 12)

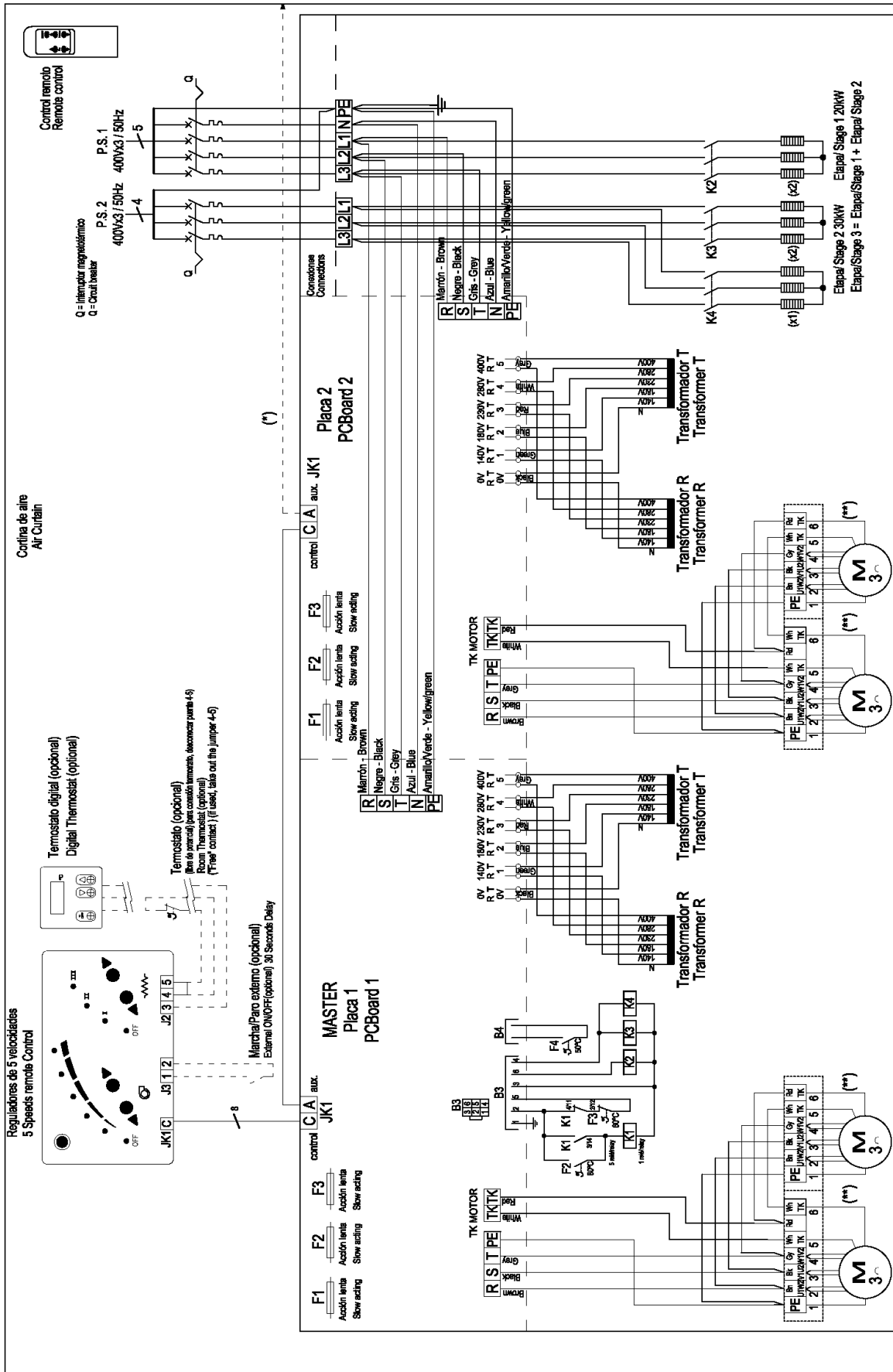

(*) Cortina 2 (opcional, máximo 12)
Air Curtain 2 (optional, Max 12)

(**) Color de los cables del motor.
Color of the motor wires:
Cable / Wire 1: yellow-green / amarillo-verde
Cable / Wire 2: brown-orange / marrón-naranja
Cable / Wire 3: blue-red / azul-rojo
Cable / Wire 4: black-grey / negro-gris
Cable / Wire 5: white / blanco
Cable / Wire 6: white / blanco

Regulación trifásica 400Vx3 50Hz Estándar
Standard Regulation 3 Phase 400Vx3 50Hz
Controlador 5 velocidades eléctrico, L 2500 E50
ELECTRICAL CONTROLLER 5 SPEEDS, L 2500 E50

Pgs./Page 1 de/ of 1
Doc. AIRDOE0962
R8 - 14/06/21

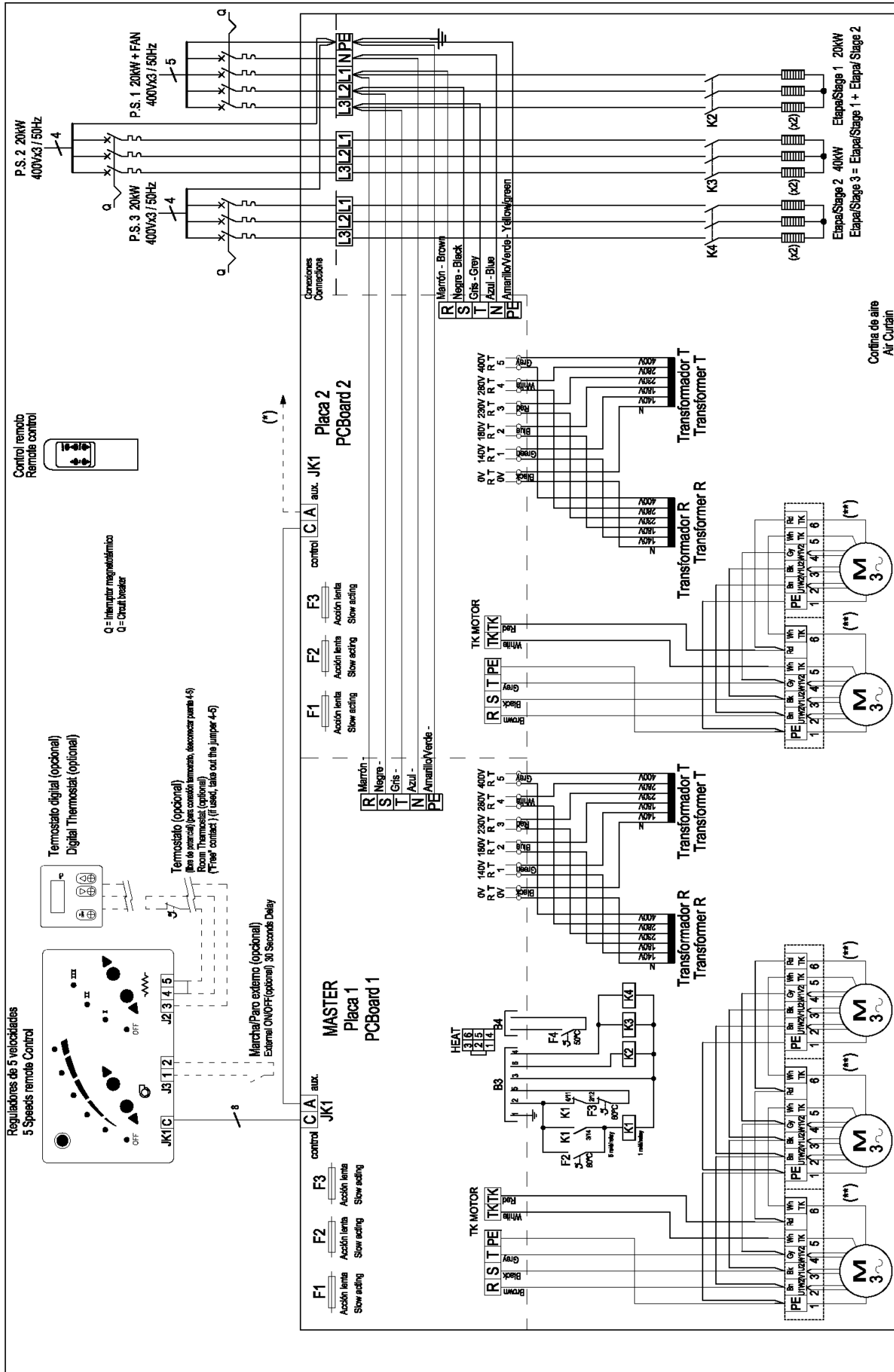

(*) Confina 2 (opcional, máximo 12)
Air Curtain 2 (optional, Max 12)

(**) Color de los cables del motor.
Color of the motor wires:
Cable / Wire 1: yellow-green / amarillo-verde
Cable / Wire 2: brown-orange / marrón-naranja
Cable / Wire 3: blue-red / azul-rojo

(***) Cable / Wire 4: black-grey / negro-gris
Cable / Wire 5: white / blanco
Cable / Wire 6: white / blanco

Regulación trifásica 400Vx3 50Hz Estándar
Standard Regulation 3 Phase 400Vx3 50Hz
Controlador 5 velocidades eléctrico, LXI, 2500 E60 y L 3000E60
ELECTRICAL CONTROLLER 5 SPEEDS, LXI, 2500 E60 and L 3000E60

Pág./Page 1 de/ of 1
Doc. AIRDCE0966
R8 - 14/06/21

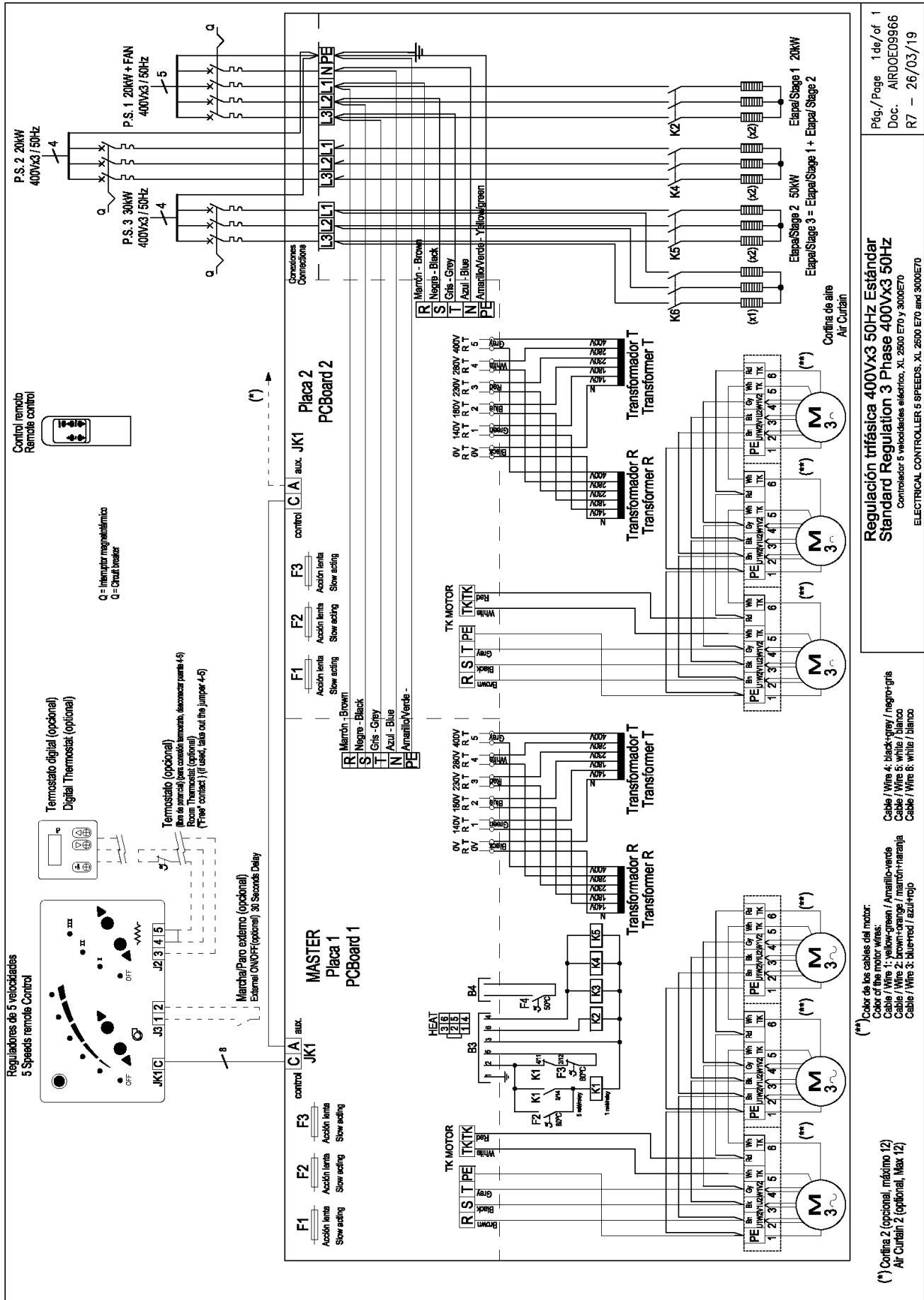

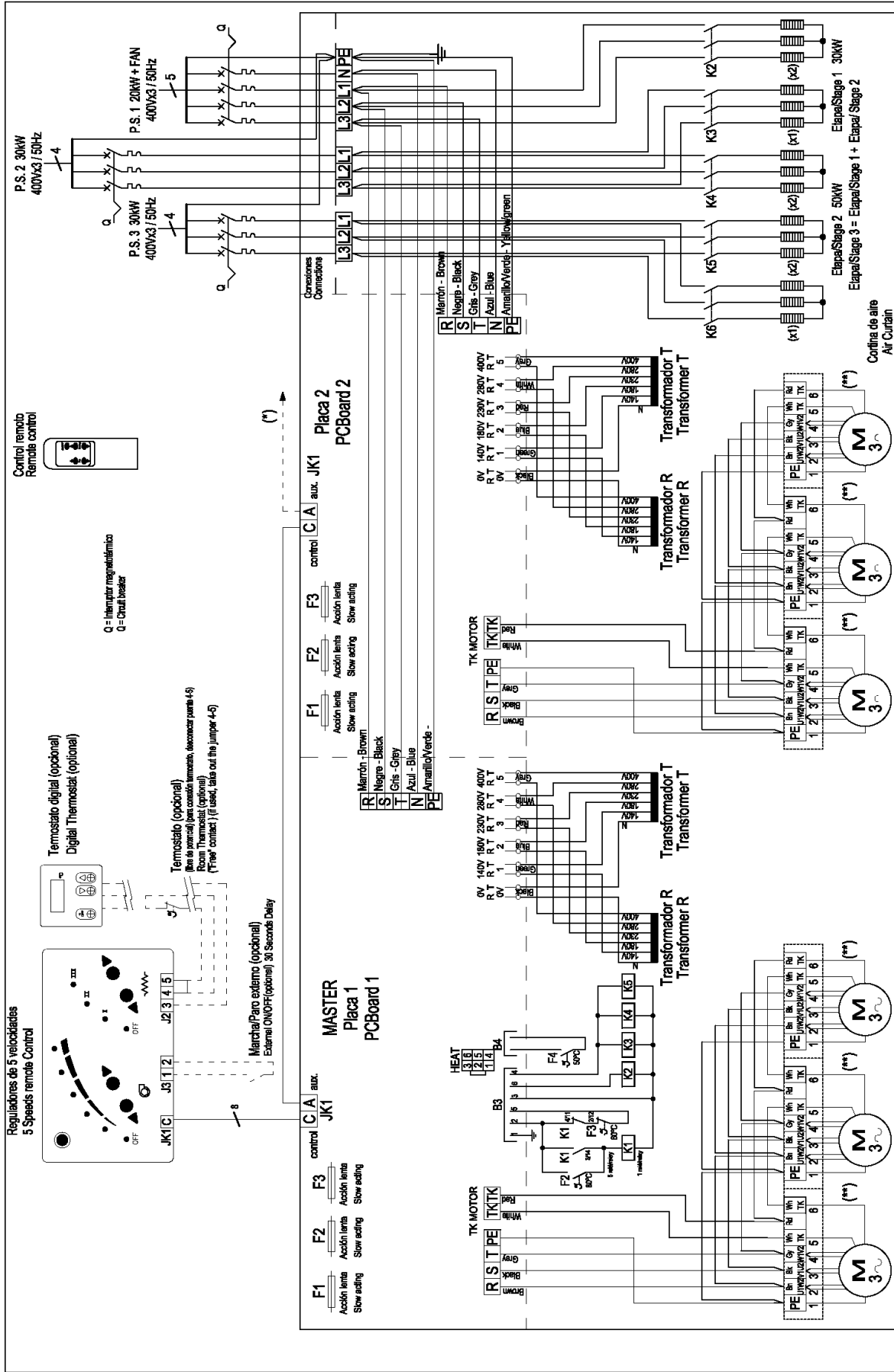



(*) Contorno 2 (opcional, máximo 12)
Air Curtain 2 (optional, Max 12)

(**) Color de los cables del motor:
Color of the motor wires:
Cable / Wire 1: yellow-green / amarillo-verde
Cable / Wire 2: brown-orange / marrón-naranja
Cable / Wire 3: blue-red / azul-rojo
Cable / Wire 4: black-grey / negro-gris
Cable / Wire 5: white / blanco
Cable / Wire 6: white / blanco

Regulación trifásica 400Vx3 50Hz Estándar
Standard Regulation 3 Phase 400Vx3 50Hz
Controlador 5 velocidades eléctrico, XL3000E80
ELECTRICAL CONTROLLER 5 SPEEDS, XL3000E80

Pág./Page 1 de/of 1
Doc. AIRDOED9970
R7 - 26/03/19

MAINTENANCE INSTRUCTIONS

	<i>For safety, before any cleaning, disconnect power supply using the controller.</i>
	<i>It is forbidden to open the service door (risk of electrical discharge and being trapped in fans). Service and maintenance should be done only by introduced and qualified workers.</i>
	<i>Do not use water or steam for cleaning the internal parts and components of the air curtain.</i>

Air curtains don't need any kind of maintenance except the cleaning of the casing and the inlet grille.

The casing of the air curtain should be cleaned with a wet cloth and non-aggressive detergent. Do not use caustic soap or acids.

The inlet grille prevents the settling of dust and strange objects in the internal elements. It is recommended to check periodically that the inlet grille is free of any object that could interfere the air entrance (plastic bags, papers, etc...)

In case of a micro drilled inlet grille (it has filter functions to prevent the entrance of dust to the internal elements) use a vacuum cleaner with a soft brush in order to avoid any damages in the micro drilled grille. We recommend cleaning the grille every two weeks (depending on the amount of the incoming air dust).



REPAIRS AND REPLACEMENTS



Installation and electrical connections must be done by qualified workers and following these instructions.

Before any repairs are undertaken, please :

- *Inform people that there is work in progress.*
- *Disconnect the power supply and protect the thermal magnet (so nobody can restart it accidentally).*
- *Make sure there is no tension in the air curtain.*
- *Make sure the fans are stationary.*
- *Use only original spare parts.*



To **open the service door**, follow these steps:

1. With a screwdriver and holding the door, remove all the screws that fix the door.



- 2 - Open the door carefully. In case of an air curtain with **plenum or inlet/outlet kits** follow the same steps,

Fan replacement

Before replacing the fan, inform people that there is work in progress, stop the air curtain through the controller and disconnect main supply. Make sure that the unit is without tension and the fans are stationary.

L: Unplug the fan from the cable tree. Remove the fan by loosening the fixing screws and assemble the new fan following the process in reverse order.

XL: Unplug the fan from the cable tree. Remove the fan by loosening the fixing screws of the platform (photo 2) to remove the air curtain (Photo 1), remove the screws of the fan and assemble the new fan following the process in reverse order.



photo 1

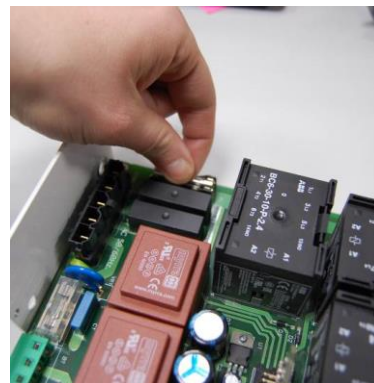
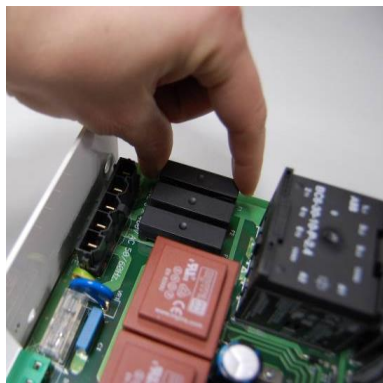

photo 2

Fuse and PCB replacement

Before the replacement, inform people that there is work in progress, Disconnect main supply, make sure that the unit is without tension and that the fans are stationary.

Fuse replacement: Open the service door, remove the fuse cover and replace the failed fuse of the fuse holder by hand or pulling with the help of a screwdriver and replace



PCB replacement: Open the service door and simply unscrew the power plate by the upper external part of the air curtain to remove it and make the necessary repairs.

Heat exchanger or coil replacement

Before change of coil or heater, inform people that there is work in progress, stop the air curtain through the controller and disconnect main supply. Make sure that the unit is without tension and the fans are stationary. Before removing the screws that fix the coil or heater, we have to:



Water element: Close the shut-off water valves of the building water circuit to the air curtain (supply and return). Open the service door..

Fixation points of coils and heaters



FAILURES AND SOLUTIONS

More than 95% of the complaints are submitted during the start of operation of the equipment and are due to **installations errors**.

More than 90% of the failures are solved only by **checking the connections**. Following the three following points, we can make sure that the installation is correct:

- A) Telephone cable is been manipulated:** The cable that connects the controller to the air curtain is an 8 lines crossed telephone cable. **If manipulated (cut or removing the connector) and incorrectly joined, the air curtain won't work.** Moreover, it can damage the electronics. If the connector is joined wrong side, we can solve the problem only by turning it (connections diagram of first page).
- B) Wrong connection of the telephone cable.** Verify whether the connector position is correct (between control or auxiliary according to the installation diagram, specially if there is more than one air curtain with a single controller).
- C) Wrong current supply / input.** The air curtain input depends on the type of current that is available and also on the heating type of the unit. Connect the unit according to the diagram on the first page

Common problems and solutions		
Effect	Problem	Solution
All lights of the IR-command are OFF	¿Is the telephone cable the original (not manipulated), with no enlargements either shortenings?	Change the cable or connect it again correctly.
	¿Does the current reaches de connection box?	Connect the terminals of the junction box correctly: Between any line and N there must be 230V and between phases there must be 400V, among the terminals L1, L2 and L3.
	¿Is the IR-command connected to the "Control" of the PCBoard?	Connect the IR-command cable to the connector "Control" at the power board, never to the "Aux". The Aux is for connect a second curtain.
	¿Are the fuses of the PCBoard in good conditions?	Check the fuses and replace it in case it is necessary (Type T, slow action 16A).
One light of the IR-command is flashing (curtains with heating)	The green LED of the maximum speed flashes when we stop the air curtain after having been operating with heating	It is not an error but a safety mechanism. The air curtain turns on by itself to the maximum speed to get cold and protect its components. When temperature decrease the safety temperature, it will stop.
	Some speed or heating lights are flashing when the air curtain is working.	It is a protection mechanism of the air curtain so that the internal parts of the air curtain do not suffer damages. Situations on which the problem continuously recurs and the way to solve/avoid it: 1. Inlet grille blocked (objects, dirtiness...) the ambient temperature inside the equipment can increase a lot if the air cannot circulate properly. Keep the grille clean. 2. Small room: We recommend installing a thermostat to control the heating power so the protection device do not activates. 3. In case that the ambient temperature is already high, we recommend to lower the power heating or install a thermostat. 4. Inlet air already warm, that comes from other heating equipment beyond the air curtain. Move the air curtain away, place a thermostat in the inlet part of the curtain or lower the heating power. 5. Any motor does not work: inform the technical service.
The heating is not working but no led is flashing (curtains with heating)	¿Does the three-phase current reach the connection box?	Check installation
	The heating crossed the safety temperature and safety relay jumped.	Check: <ul style="list-style-type: none"> • Clean grille and without obstacles • All motors are working • The ambient temperature is not too high • Do a reset cutting temporally the tension.

The speed and/or the heat changes continuously with no apparent reason but the lights of the IR-command are not flashing.	Probably the telephone cable is near interference sources, transmitters, cable plates, specially those that supply current to the Motors, etc..	Pass the cable the furthest possible away from the interference source, specially when long distances or use a screened cable.
The 5 speed LED's of the controller flashing sequentially	Reason: <ul style="list-style-type: none"> The phases are switch or any phase no have current. Some the fuses of the board have melted. 	<ul style="list-style-type: none"> This can occur during the installation or afterwards for a breakdown in the supply that feeds the building The protection consists in a blocking forced stop, the curtain will no working. To make the curtain work again solve the problem and reset cutting temporally the tension
All the LEDs blink together.	Lack of internal current: <ol style="list-style-type: none"> Contactora fail Toroid transformer Wires Motor winding 	<p>The protection consists in a blocking forced stop one of the contactors.</p> <p>Do the following steps:</p> <ol style="list-style-type: none"> Check all 4 fuses Check the air curtain wires Disconnect the white-red-blue-green wires to the transformer and check the voltage (between black wire and the rest, in the transformer label have the correct voltages) Fan state <p>If the rest of points are good replace the board. Correct the problem and the curtain only works after the rest cutting temporally the tension.</p>
LEDs light alternately odd-even	Motor temperature overrun	<p>Due to:</p> <ul style="list-style-type: none"> short circuits in the wound Mechanical problems Aspiration problems. Air obstruction The protection consists in a forced stop, the curtain no working while any of the fans have a temperature excess. The curtain returns to working after cooling.

Interchange phases annex

OK			
Connection Box	1	2	3
Correct 1	L1	L2	L3
Correct 2	L3	L1	L2
Correct 3	L2	L3	L1

NOK			
Connection Box	1	2	3
No correct 1	L1	L3	L2
No correct 2	L2	L1	L3
No correct 3	L3	L2	L1

Like can see at the boards, in the case of the wrong connexions NOK, you can fix the problem changing two phases. After change you have a correct connection OK.

ACCESSORIES



Control Clever

Intelligent proactive regulation, advanced functions, Automatic/manual working, door delay, timer, save energy program, multi equipment management, BMS Modbus connection, etc.

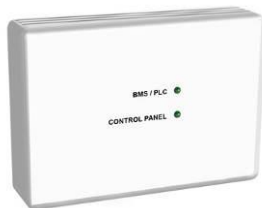

Interface

Allows the connection to a centralized management system (BMS, PLC, etc...).



External temperature probe

It permits to take the temperature from a place different to the control.

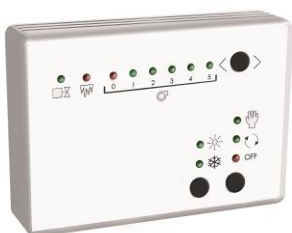

Hand Auto (water heated)

It permits to connect anti-freezing sensors, door contact, ambient thermostat..



Room Thermostat

It limits the operating of the heating to the selected one.

Supports, feet, vibration dampers...etc... depending on the model.

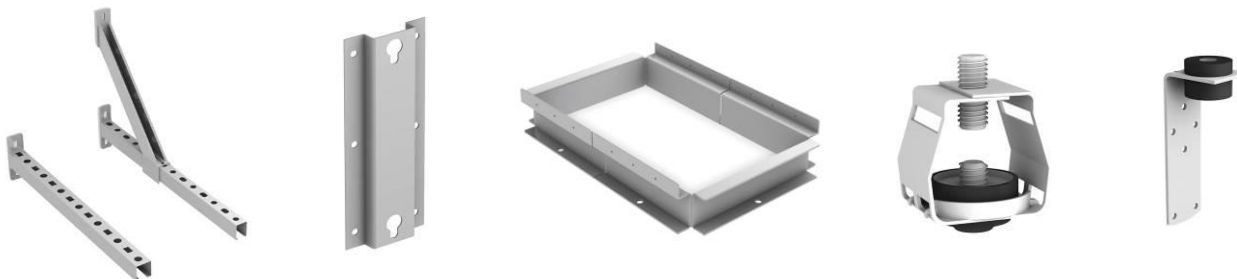

Door contact, thermostatic valve, solenoid valve, antifreezing sensor



Telephone Cable 50m,



Plenum and/or inlet/outlet kit (depending on the model)

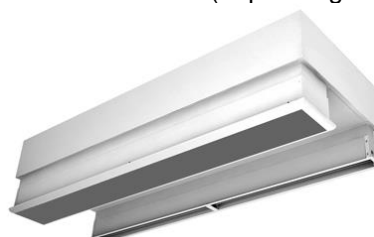

DECLARATION OF CONFORMITY



Declaration CE of conformity / Declaración CE de conformidad

Manufacturer **Motors i Ventiladors S.L. (AIRTÈCNICS)**
Fabricante **Conca de Barberà 6, Pol. Ind. Pla de la Bruguera**
08211 Castellar del Vallès (Barcelona) Spain

We declare, under our sole responsibility, that the product(s)
Declaramos, bajo nuestra única responsabilidad, que el/los producto(s)

Air Curtains
Cortinas de aire

with models
con los modelos

Minibel, Optima, Recessed Optima, Windbox, Recessed Windbox, Smart, Dam, Deco, Kool, Variwind, Rotowind, Invisair, Rund, Zen, Duojet, Triojet, Max, Recessed Dam, Recessed Compact, Maxwell

is/are developed, designed and manufactured in accordance with the following directive(s)
ha(n) sido desarrollado(s), diseñado(s) y fabricado(s) de acuerdo con la(s) siguiente(s) directiva(s)

Low Voltage Directive 2006/95/EEC
Directiva Baja Tensión 2006/95/CEE

Electromagnetic Compatibility Directive 2004/108/EEC
Directiva Compatibilidad Electromagnética 2004/108/CEE

Restriction Certain Hazardous Substances Directive 2011/65/EU (RoHS)
Directiva Restricción Substancias Peligrosas 2011/65/EU

Eco-design Energy-related Products Directive 2009/125/EC
Directiva Diseño Ecológico Productos Con Energía 2009/125/CE

applying the following harmonized standards in particular
aplicando las siguientes normas armonizadas en particular

LVD: EN 60335-1:2012 + AC: 2014 + A11: 2014
EN 60335-2-30:2009+A11 :2012

EMC: EN 61000-6-2:2005
EN 61000-6-3:2007+A1:2011
EN 55014 -1:2006+A1:2009+ A2:2011
EN 55014 - 2:1997+A1:2001+A2:2008

RoHS: EN 50581:2012

Date / Fecha
Name / Nombre
Position / Cargo

10/09/2015
Jordi Oltra Orta
General Manager / Director General

AIRTÈCNICS
MOTORS I VENTILADORS, S.L.
B58967183 - C/ Conca de Barberà, 6
08211 Castellar del Vallès
Tel. 937159988 - Fax 937159989



Model Modelo	WINDBOX M 2000 E				
Airflow Caudal	3600	m3/h			
Blowers Ventiladores	1,88	A	0,424	kW	230 V/50Hz

Heating capacity Calificación	80/60 °C	60/40 °C		
Water Coil Agua		kW		kW
Electric Coil Batería Eléctrica	6/12/18	kW	400V~3	50Hz

Serial Number Número de Serie	2015-07-06 / 61.990
---	---------------------

Air curtain identification:

Each air curtain is identified by a unique serial number printed in a label located inside the door service.

There is also indicated the model and their technical characteristics (flow, fans technical characteristics and power heating)

It is indispensable to have this number to facilitate possible replacements or technical information of the air curtain in question

WARRANTY

Your air curtain is guaranteed for a period of one year from the date of purchase. We will adjust, repair or replace at our discretion from our warehouse any defect, system failure or part found to be defective. The assembly cost out of our warehouse is at buyer expense. The products that, in our eyes, have been inadequately used, incorrectly manipulated, improperly installed, connected to different nominal tensions, modified, repaired by non-authorized workers or that have suffered damages during transport are totally excluded from the guarantee.

To validate the guarantee it should be correctly filled and enclosed with the invoice that vouches for the buying date. If it is manipulated, it will lose all validity.

It is the buyer's responsibility to take the necessary safety measures because in case of a failure or mistake in one of our products, no damages to third parties, sets or installations will occur.

✍

Guarantee draft

Air curtains data:

Model: Series number:.....

Invoice date: Invoice number:

Buyer data:

Name:

Address:

Country: Phone: Fax:

Seller data:

Name:

Address:

Country: Phone: Fax:

Buyer signature and stamp

Seller signature and stamp